



Basic Irrigation Design

Student Edition



TABLE OF CONTENTS

Introductionii
Terminologyiii
System Diagram1
Hydraulics2
 ■ Water Pressure2
 ■ Static Pressure3
 ■ Friction Loss3
 ■ Velocity5
 ■ Review6
Available Water7
 ■ Bucket Test9
 ■ Review10
Sprinkler Layout11
 ■ Sprinkler Application11
 ■ Sprinkler Distribution Curve11
 ■ Square/Rectangular Layout12
 ■ Triangular Layout12
 ■ Steps for Laying Out Sprinklers13
 ■ Review14
Zoning A System16
 ■ Pipe Routing17
 ■ Locating Valves17
 ■ Review18
Pipe Sizing20
 ■ Review21
System Operation Check22
 ■ Review25
Design Checklist27
Suggested Readings28



Basic Irrigation Design

■ Introduction

The Toro Company is proud to present Basic Irrigation Design. This workbook guides you, step-by-step, through the process of designing an effective and efficient irrigation system.

In order to understand the process of irrigation design, there must first be a fundamental knowledge of the important irrigation components and their relationships to one another. Each element of an irrigation system has a direct effect on how the system operates as a whole. If some components are undersized or misused, the system may not operate properly. This may result in poor distribution of water and less-than-optimum growth for the plant material.

When a project is designed and installed using the proper guidelines, the result is an efficient, long-lasting irrigation system — a system of which you can be proud.



When asked to refer to the Toro Specification Catalog it means to use the most current version of the the Toro Product Catalog available on-line or your local profession Toro irrigation distributor.

Backflow Prevention Device — the device, required by law, on an irrigation system that prevents water from re-entering the potable water lines once it flows into the irrigation pipes.

Controller — the device that sends timing commands to remote control valves for actuation.

Coverage — the pattern of water applied to an area by a sprinkler head.

Design Operating Pressure — the pressure a designer uses to determine spacing distances and flow for sprinkler heads. The design operating pressure is determined by subtracting estimated friction losses from the static water pressure.

Dynamic Pressure — the pressure reading in a pipeline system with water flowing.

Flow — the movement of water through the irrigation piping system; causes friction loss.

FPS — the abbreviation for "feet per second"; refers to the velocity of water in pipes.

Friction Loss — the loss of pressure (force) as water flows through the piping system.

GPM — the abbreviation for "gallons per minute" (unit of measure for water flow).

Head-to-Head Spacing — refers to the spacing distances of sprinklers when they do not exceed the radius of the sprinklers.

Lateral — the pipe in an irrigation system located downstream from the remote control valve. Lateral pipes carry water directly to sprinklers.

Main Line — the pipe in an irrigation system that delivers water from the backflow prevention device to the remote control valves. This is usually the largest pipe on the irrigation system, generally under constant pressure and located upstream from the remote control valves.

Manifold — a group of control valves located together in the same area.

PSI — the abbreviation for "pounds per square inch" (unit of measure for water pressure).

PVC Pipe — Poly Vinyl Chloride pipe; the most common pipe used in irrigation systems.

P.O.C. — abbreviation for "point of connection." This is the location on the irrigation system where a tap is made for connection of a backflow prevention device or water meter.



NOTES

Potable Water — water used for drinking purposes.

Precipitation Rate (PR) — the rate at which sprinkler heads apply water to a specific area of coverage, over a given period of time, measured in inches per hour.

Remote Control Valve — the component in the irrigation system that regulates the on/off of water from the main line to the sprinkler heads; activated by the controller.

Service Line — the pipe supplying water from the city water main to the water meter.

Spacing — the distance between the sprinkler heads or the sprinkler head rows.

Static Water Pressure — the pressure that exists in a piping system when there is no flow; measured in pounds per square inch (PSI).

Station — a group of sprinkler heads that is controlled by the same remote control valve; same as a zone.

Surge — the build-up of water pressure in a piping system due to certain characteristics of the pipe, valves and flow.

Velocity — the speed at which water flows through the piping system; measured in feet per second (FPS).

Water Main — the city water pipe located in the street or right-of-way.

Water Pressure — the force of water that exists in a piping system; measured in pounds per square inch (PSI).

Working Pressure — the remaining pressure in the irrigation system when all of the friction losses are subtracted from the static pressure.

Zone — a group of sprinkler heads that are controlled by the same remote control valve; same as a station.

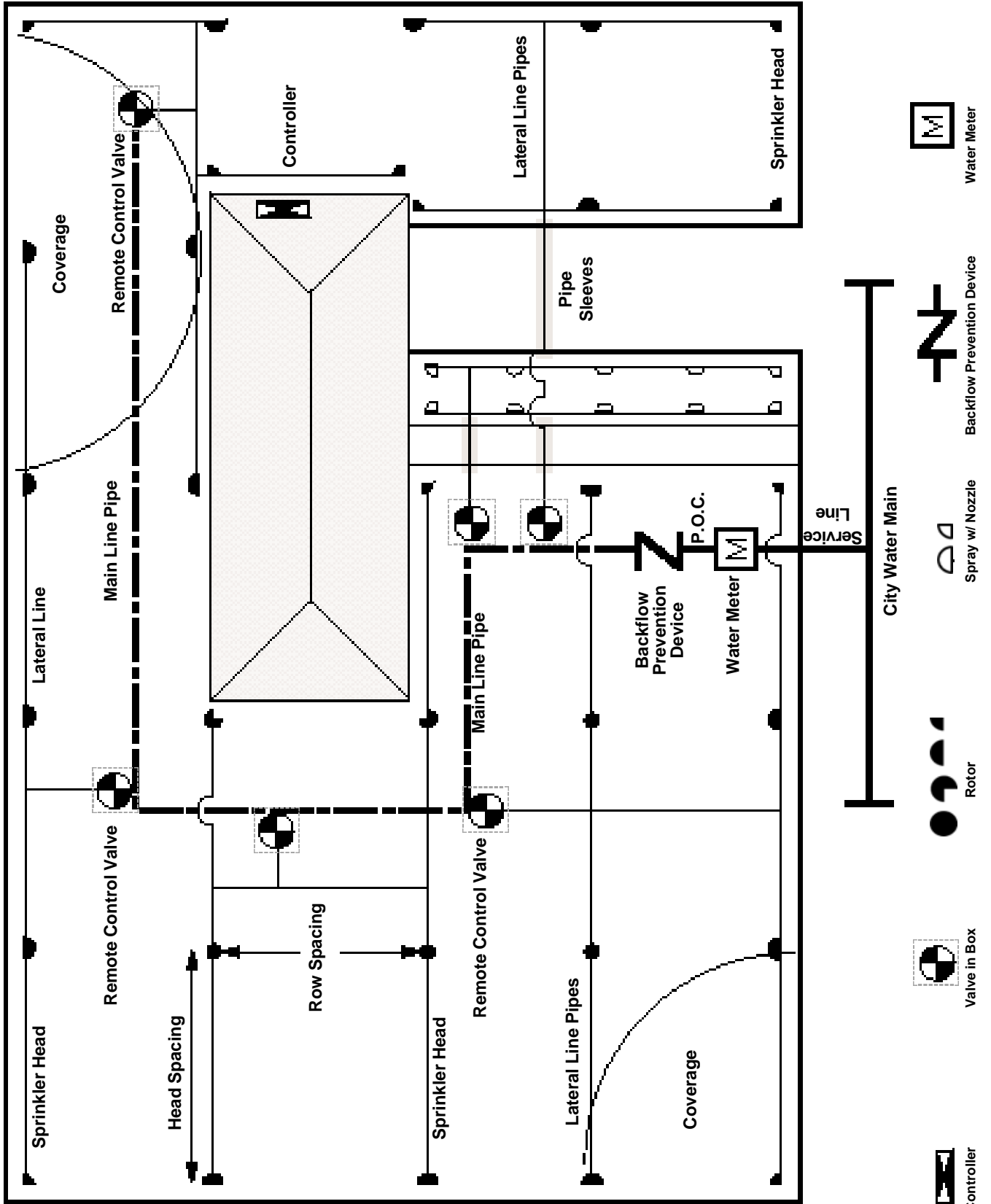



It is important to understand hydraulic principles before beginning an irrigation design. This section includes an explanation of water pressure, friction loss and water velocities. When you understand hydraulics, you then understand the physical properties of water and how they affect the operation of irrigation systems.

Water Pressure

Water pressure is the force or exertion of water in a piping system. Pressure is created by increasing the height (downward force due to weight) of the water or by using a mechanical booster pump. Pressure is measured in pounds per square inch (PSI).

One gallon of water weighs 8.3 pounds. There are approximately 7.5 gallons of water in a cubic foot. Therefore, a cubic foot of water has a total weight of 62.25 pounds. One cubic foot equals 1,728 cubic inches. When the weight of water in a cubic foot is converted to cubic inches, it weighs .036 pounds per cubic inch.

$$62.25 \text{ lbs.} / 1728 \text{ cu. in.} = .036 \text{ lbs./cu. in.}$$

By multiplying the weight of one cubic inch (.036 pounds) by 12 inches, it produces a force of .433 PSI for one foot of elevation. The pressure is measured at the base of the 12-inch column, which is the same as a square inch that is 1 foot high.

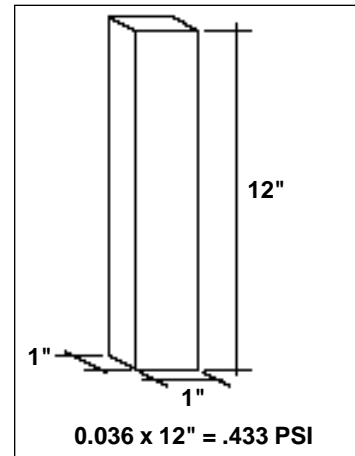

FIGURE 1.1

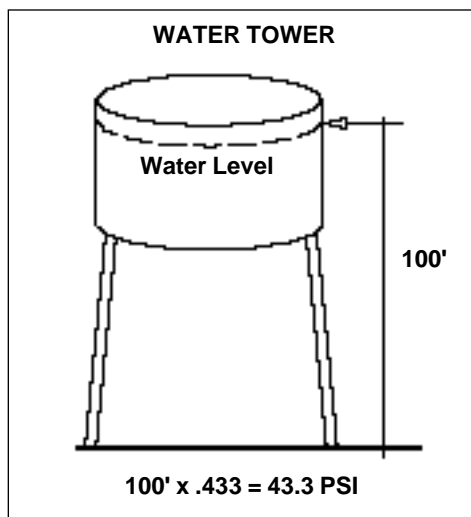

FIGURE 1.2

When the column of water increases in height, the weight, force and pressure also increase. By multiplying the height of the water by .433 the pressure can be calculated. Therefore, a 100-foot column of water creates 43.3 PSI.

NOTES

Static Pressure

Static pressure is the amount of water force that is measured in a closed or non-flowing water system. This pressure is measured by attaching a pressure gauge to a hose faucet. With no water flowing in the piping system, static pressure is determined. When there are no hose bibs from which to measure, a call to the local Public Works or Fire Department can usually provide the static readings.

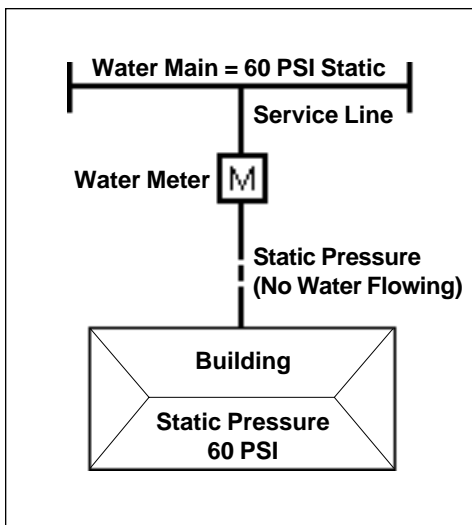

FIGURE 1.3

On a level site, the static pressure in the main will be approximately the same as the static pressure at the building.



Knowing static pressure is essential before beginning any design.

When water begins to flow in a piping system that was once static, the pressure reading on the gauge will drop. The pressure reading with water flowing is referred to as **dynamic pressure**.

Friction Loss

Friction loss is the reduction in water pressure once water begins to flow through the piping system. Pressure loss occurs when flowing water comes in contact with the inside surface of the pipe and other devices. The rougher the inside surface, the more friction loss it will create. Friction loss may also occur due to increased flow in the pipes.

Loss of water pressure occurs when water flows through the following components:

- service line
- water meter
- backflow prevention device
- main line pipe
- remote control valve
- lateral line pipe
- fittings
- other devices on the system

An estimate of the amount of friction loss on the site is required prior to designing the system.



NOTES

Friction Loss (CONTINUED)



On a residential or small commercial water system, there is typically 20 to 25 PSI loss due to friction from the water main to the last sprinkler.

By taking the known static water pressure and subtracting the estimated friction loss, a maximum **design operating pressure** is determined for the sprinkler heads.

For example, if static pressure equals 60 PSI and the estimated friction loss is 20 PSI, the maximum sprinkler design operating pressure should be between 35 and 40 PSI.

Friction losses in pipe are calculated using the following information:

- type of pipe
- size of pipe
- length of pipe
- amount of water flowing through the pipe

Use the *Toro Specification Catalog* to determine exact friction losses for different types of pipe, water meters and gate valves. Friction losses for 100-foot lengths of pipe are listed. To convert friction losses to the exact length of pipe, the loss per 100-foot length is multiplied by a decimal factor of the actual length.

Refer to Figure 1.4 below (from the *Toro Specification Catalog*), 3/4" Class 200 PVC pipe flowing 10 GPM has a loss of 4.79 PSI per 100 feet. Therefore, 63 feet of 3/4" pipe has a loss of 3.09 PSI.

$$4.79 \times 0.63 = 3.0177 = 3.02 \text{ PSI loss}$$

Pressure Loss From Friction per 100' of Pipe (lbs./sq. in.)									
SDR 21 / Class 200 PVC 1120, PVC 1220, PVC 2120 C = 140									
Flow GPM	1/2	3/4	1	1 1/4	1 1/2	2	2 1/2	3	4
1	0.25	0.49							
2	0.90	0.24							
3	1.90	0.52							
4	3.24	0.88	0.26						
5	4.89	1.33	0.39						
6	6.86	1.86	0.55						
7	9.12	2.47	0.73						
8	11.68	3.17	0.94	0.30					
9	14.53	3.94	1.17	0.37					
10	17.66	4.79	1.42	0.45	0.23				

FIGURE 1.4

NOTES

Velocity

Velocity is the speed at which water flows through components of a system. Velocity is measured in feet per second (FPS). When designing PVC irrigation systems, it is best to maintain velocities of 5 FPS or less. This reduces the chance of developing **surge pressures** in the piping system.

Velocity information is found in the *Toro Specification Catalog* in the column adjacent to the friction losses for a particular type of pipe.

Refer to Figure 1.5 below (from the *Toro Specification Catalog* 3/4" Class 200 PVC pipe flowing 10 GPM has a velocity of 4.93 feet per second. This is a safe velocity of flow for 3/4" PVC pipe because it is under 5 FPS.

Velocity of Flow (Ft./Sec.)									
SDR 21 / Class 200 Plastic Pipe									
Flow GPM	1/2	3/4	1	1 1/4	1 1/2	2	2 1/2	3	4
1	0.84	0.49							
2	1.68	0.99							
3	2.53	1.48							
4	3.37	1.97	1.19						
5	4.21	2.46	1.49						
6	5.05	2.96	1.79						
7	5.90	3.45	2.09						
8	6.74	3.94	2.39	1.49					
9	7.58	4.43	2.69	1.67					
10	8.42	4.93	2.99	1.86	1.41				
12	10.11	5.91	3.58	1.23	1.69				

$$V = 144 \frac{Q}{A_1}$$

FIGURE 1.5



Review

1. How much pressure is created at the base of a 10-foot column of water?
_____ PSI
2. Approximately how much friction loss will occur when water flows from the water main to the last sprinkler on the system?
_____ PSI
3. What is the maximum safe velocity of water through PVC pipe?
_____ FPS
4. Calculate static pressure at the base of the tower.

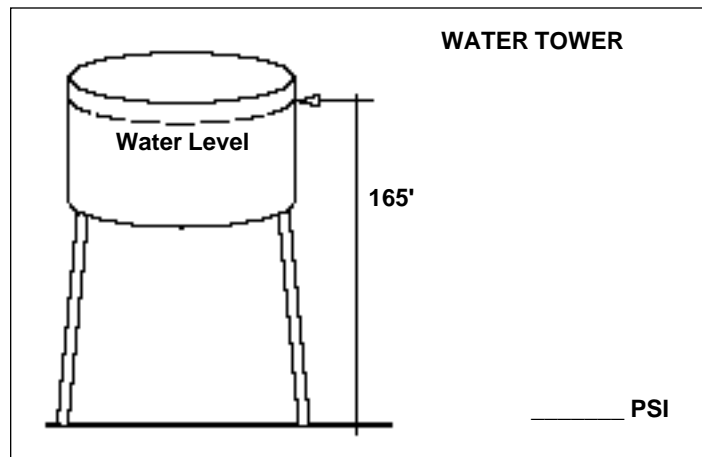

FIGURE 1.6

5. Determine the water pressure at each location on the piping system. The water is in a static (no flow) condition.

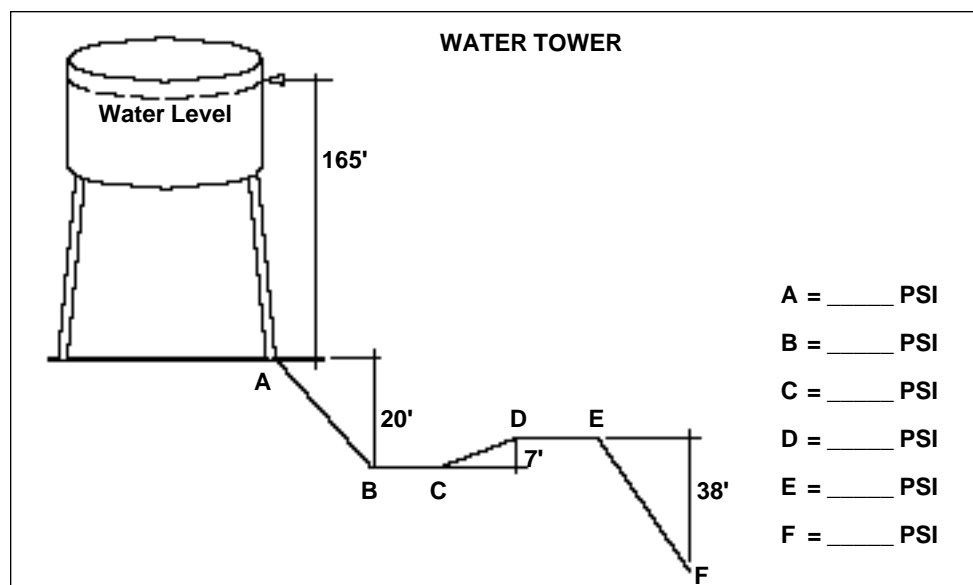

FIGURE 1.7



The purpose of this section is to determine the safe amount of water that flows through the water meter and the service line for use by the irrigation system. This section includes a field checklist and calculations used to determine available water. By limiting the amount of water flowing through both the meter and the service line, the friction losses through these components are limited as well. Once the available water is determined, the number of sprinklers that operate from the same valve are then calculated. Correctly calculating available water prevents the system from excessive friction losses occurring in the water meter and service line.

A field inventory of components is necessary before beginning. The following should be checked in the field:

1. The meter must be located and checked for size. The size is usually stamped on the side of the meter.
2. The service line from the city main to the meter should be examined for the type of material, diameter size and length of run. If the service line is made of copper, a string test will determine the exact diameter size. Place a string around the pipe and measure the length of string. Compare to the following:

String Length	Pipe Size
2 ³ / ₄ "	³ / ₄ "
3 ¹ / ₄ "	1"
4 ³ / ₈ "	1 ¹ / ₄ "

Once the components in the field are checked, refer to the *Toro Specification Catalog* to determine the safe flow.

To determine available water:

1. The pressure loss through the water meter should not exceed 10% of the static pressure.
2. The velocity of water should be maintained below 5 or 7 FPS in the service line, depending on the length of run from the city main to the meter.

First, refer to Figure 2.2 on page 8 (from the *Toro Specification Catalog*) for the PRESSURE LOSSES THROUGH WATER METERS.

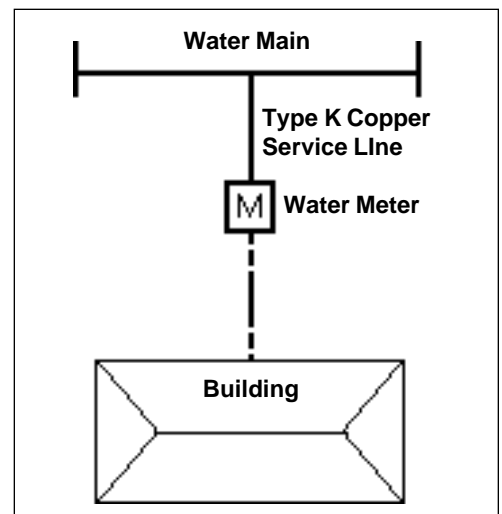

FIGURE 2.1

Calculate 10% of the static water pressure on the site. If the static pressure is 50 PSI, then 10% equals 5 PSI. Find the appropriate WATER METER SIZE at



NOTES

the top of the page. Read down this column to the pressure loss closest to, but not exceeding, 5 PSI. From this point, go to the far left column (FLOW GPM) and note this flow.

V. Pressure Losses Through Water Meters
Pressure Losses Through Standard Water Meters
Pounds per Square Inch

Flow GPM	%	¾	1	1¼	1½	2	2½	3	4	
1	0.2	0.1		Not Standard Meter Size			Not Standard Meter Size			
2	0.3	0.2								
3	0.4	0.3								
4	0.6	0.5	0.1							
5	0.9	0.6	0.2							
6	1.3	0.7	0.3							
7	1.8	0.8	0.4							
8	2.3	1.0	0.5							
9	3.0	1.3	0.6							
10	3.7	1.6	0.7							
11	4.4	1.9	0.8			0.1				
12	5.1	2.2	0.9			0.2				
13	6.1	2.6	1.0			0.2				
14	7.2	3.1	1.1			0.3				
15	8.3	3.6	1.2			0.3				
16	9.5	4.1	1.4			0.4				
17	10.7	4.6	1.6			0.4				
18	12.0	5.2	1.8			0.5				
19	13.4	5.8	2.0			0.6				
20	15.0	6.5	2.2			.07				
22		10.3	3.7			.08		0.4		
24		15.0	5.3			1.3		0.5		
26			7.3			1.8		0.7		
						2.6		1.0		

FIGURE 2.2

Prior to determining safe flow through the service line, check the length of service line pipe from the city water main to the connection for the backflow prevention device. If the run is less than 35 feet, the maximum velocity may be 7 FPS. If the run of service line is more than 35 feet long, the velocity should be maintained at 5 FPS or less. This is done to prevent excessive friction loss in long runs of service lines.

Next, refer to the page under VELOCITY OF FLOW for the type of pipe used. Refer to Figure 2.3 on page 9 (from the Type K Copper Tube of the Toro Specification Catalog). Locate the appropriate pipe size at the top of the page. Read down the column to the velocity of either 5 or 7 FPS, depending on the length of the service line. From this point, go to the far left column (FLOW GPM) and record the safe flow through the service line.



Compare the safe flow (GPM) from the water meter and the safe flow (GPM) from the service line. Use the lower GPM as the amount of available water that should be used in the design of the system.

NOTES

Velocity of Flow (Ft./Sec.)									
TYPE K COPPER TUBE									
Flow GPM	$\frac{1}{2}$	$\frac{3}{4}$	1	$1\frac{1}{4}$	$1\frac{1}{2}$	2	$2\frac{1}{2}$	3	4
1	1.47	0.74							
2	2.94	1.47							
3	4.41	2.21							
4	5.88	2.94	1.65						
5	7.35	3.68	2.06						
6	8.81	4.42	2.48						
7	10.28	5.15	2.89						
8	11.75	5.89	3.30	2.11					
9		6.62	3.71	2.37					
10		7.36	4.13	2.64					
11		8.10	4.54	2.90					
12		8.83	4.95	3.16	2.23				
14		9.57	5.36	3.43	2.42				
16		10.30	5.78	3.69	2.61				
18		11.04	6.19	3.95	2.79				
20		14.72	8.25	5.27	3.72	2.13			

FIGURE 2.3

For example, consider a site consisting of a $\frac{3}{4}$ " water meter, 25-foot-long, $\frac{3}{4}$ " Type K copper service line and static pressure of 50 PSI. Then, refer to Figure 2.2. Ten percent of 50 PSI is 5 PSI. Reading down the $\frac{3}{4}$ " METER SIZE column from the top of the page, the friction loss closest to 5 PSI is 4.6 PSI. The corresponding flow with 4.6 PSI loss in the meter is 17 GPM. This is read from the FLOW GPM column at the left side of the page.

Since the service line is only 25 feet long, the maximum velocity may be 7 FPS. Refer to Figure 2.3 and locate the $\frac{3}{4}$ " column and read down to the point that does not exceed 7 FPS. At 6.62 FPS, the corresponding flow is 9 GPM. This is read from the FLOW GPM column. Since the safe flow through the water meter is 17 GPM and the safe flow through the service line is 9 GPM, the amount of available water is 9 GPM, the lower of the two numbers.

Bucket Test

Another way to verify available water and working pressure is to conduct a bucket test. This requires the use of a five-gallon bucket and a pressure gauge. Attach the gauge to a hose faucet on the site. Another hose faucet is turned on downstream from the pressure gauge hose faucet. Collect water in the bucket for one minute.

While the bucket is collecting water, a reading of working pressure is taken at the pressure gauge. This test tells you the amount of water available, measured in gallons per minute, as well as the dynamic pressure in the service line and meter.



NOTES

Review

1. What is the maximum acceptable friction loss through a water meter?

2. What is the maximum velocity of water through a service line that is greater than 35 feet in length? _____ FPS
3. Which flow becomes the available water, the higher or lower amount?

4. What is the maximum safe flow through a 1½" water meter with static pressure of 60 PSI? _____ GPM
5. Determine the available water in the following examples:

A. Static Pressure = 60 PSI

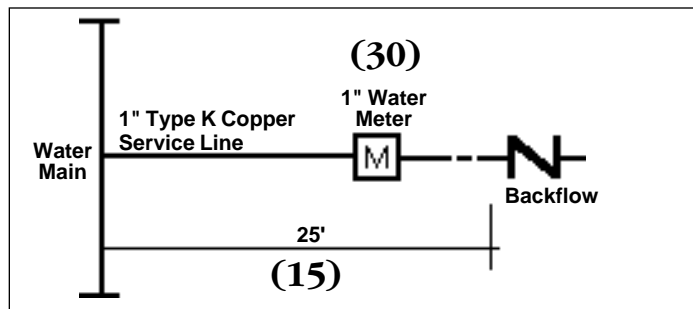

FIGURE 2.4

B. Static Pressure = 50 PSI

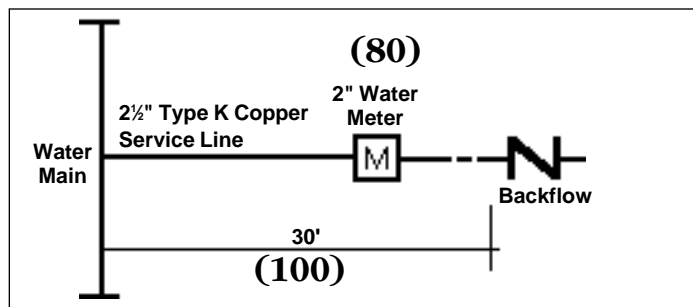

FIGURE 2.5

C. Static Pressure = 70 PSI

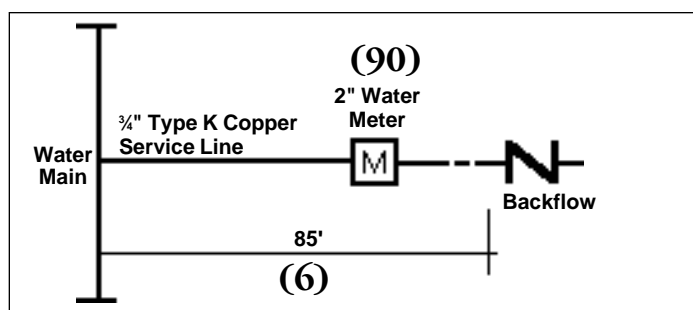

FIGURE 2.6



Mastering sprinkler layout guarantees that your system will distribute water evenly over irrigated plant material.

This section covers the basic rules and methods used for various layout styles. Irrigation systems with proper head layout produce an even growth rate of plant material.

There are many ways to lay out sprinklers on a site. Each method will work as long as specific rules are applied to each layout. Many new designers believe there is only one way to place sprinklers on a site. This is not true!



Sprinkler coverage must overlap to effectively and efficiently irrigate an area. All sprinklers have an ever-decreasing application of water as the distance increases from the head. Applied water decreases because the total square footage increases farther from the sprinkler.

Sprinkler Distribution Curve

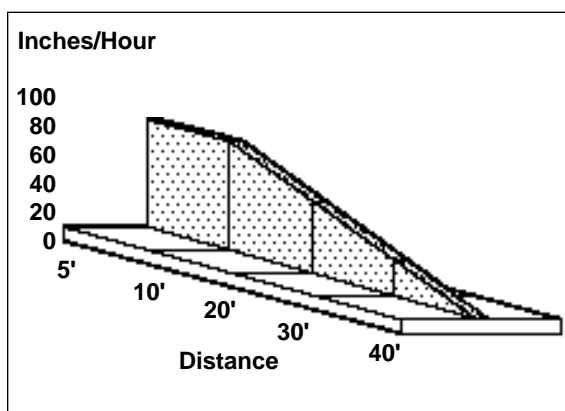

FIGURE 3.1

Sprinkler Application

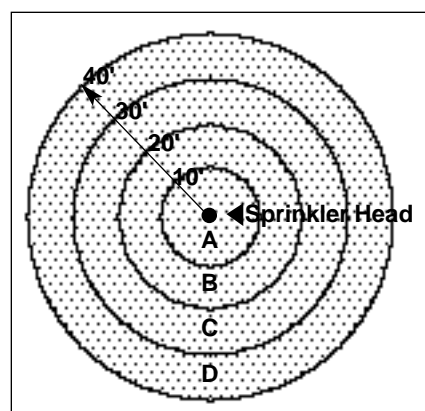

FIGURE 3.2

- A = 314 sq. ft. (6%)
- B = 942 sq. ft. (19%)
- C = 1571 sq. ft. (31%)
- D = 2199 sq. ft. (44%)

Recommendations for spacing considerations are based on wind conditions. The range of spacing can be from 45% to 60% of the diameter, depending on the wind. The stronger the prevailing wind, the closer the sprinklers should be spaced. In most situations, it is best to maintain a spacing of close to 50% of the diameter of the sprinkler throw, or 100% of the radius. This is often referred to as "**head-to-head**" spacing.

The rules that must be followed when laying out sprinklers apply to the different layout styles that are used. The two basic styles of sprinkler layout are square/rectangular and triangular. There are uses and rules for both.



NOTES

Square/Rectangular Layout

This layout is well-suited to very defined, geometric spaces, such as small, rectangle-shaped yards, or sites divided by sidewalks and other paved areas.

Square/rectangular spacing of heads also protects all borders from overthrow of water by placing sprinklers in the corners and along the perimeters. The remaining sprinklers are then used to fill between the corners evenly.

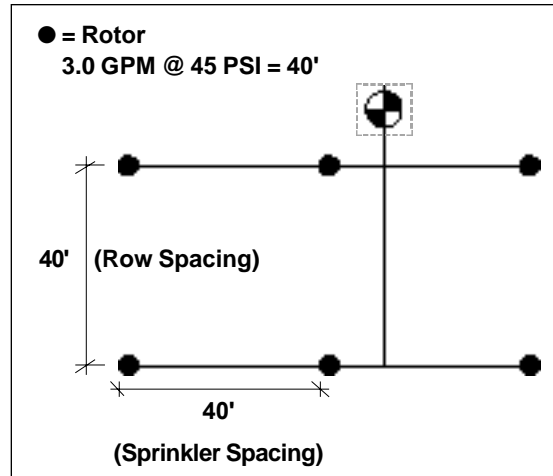

FIGURE 3.3



The primary rule for square/rectangular layout design is that the recommended distance from one sprinkler to the next should not exceed the radius of the sprinkler.

In order to best fit the site, it may be necessary to adjust the spacing. It is, therefore, acceptable to increase or decrease spacing of spray heads ± 1 foot. Rotary sprinklers may be adjusted ± 3 feet. If the sprinkler spacing is increased, do not increase the row spacing. Conversely if row spacing is increased, do not increase sprinkler spacing.

For example, the *Toro Product Catalog* indicates that a Rotor sprinkler discharges 3 GPM at 45 PSI with a radius of 40 feet. Therefore, the maximum recommended spacing from one sprinkler to another is 40 feet (see Figure 3.3).

The maximum recommended row spacing is also 40 feet. After finding the spacing distance, it is acceptable, depending on the plant type and wind, to adjust spacing between sprinklers and rows to fit the site. This produces the rectangular shape in the layout.

Equilateral Triangular Layout

Equilateral Triangular layout means all sides are equal lengths. It is a good choice for sites without borders or open areas where overthrow of water is not a problem. The actual coverage from triangular spacing of sprinklers tends to provide better overall coverage versus square spacing. The main disadvantage is the edge of coverage where an oddly spaced sprinkler will throw water beyond the edge of the site.

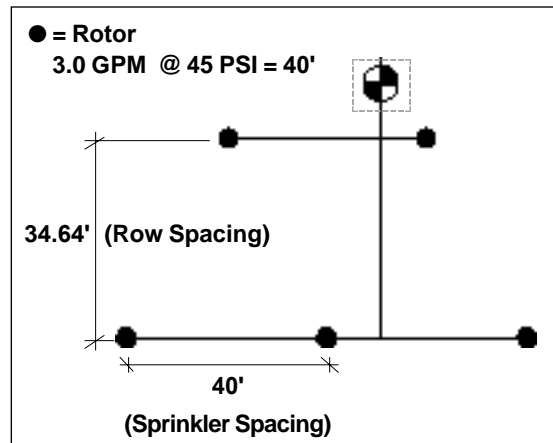

FIGURE 3.4

NOTES

Most designers space sprinklers at 50% to 55% of the sprinkler diameter using triangular spacing. The row distance is then calculated by multiplying the actual distance between sprinklers by .866. This provides the recommended distance to the next row. As with square spacing, these distances are recommended, and similar adjustments can be made to suit the size and shape of the site.

When using a Toro Rotor sprinkler set to 3 GPM operating at 45 PSI, the radius is 40 feet. Diameter equals two times the radius. Therefore, the diameter is 80 feet. By taking 50% of the diameter (.50 x 80'), the calculated distance between sprinklers is 40 feet. The row distance is calculated by multiplying 40 feet by .866. This distance is calculated to be 34.64 feet. Adjustments can be made to compensate for specific site requirements.

Steps for Laying Out Sprinklers

1. Determine the static pressure of the site. Estimate the friction losses through the system and the design operating pressure of the sprinklers.
2. Measure the site. Break the entire site into smaller geometric shapes for different layouts and sprinklers. Consider plant material and varying watering needs. Determine which layouts are best for the site: square, rectangular or triangular.
3. Determine which sprinklers will be used, the operating pressure and the maximum spacing.
4. Identify the **critical line** of the site. This is the line of sprinklers that must protect a border such as a street or building.
5. Identify the **critical corner** of the first line of sprinklers (the combination of the critical line and an adjacent border). This could be the corner of two streets, or the corner of a street and driveway, sidewalk or neighboring property.
6. Place the first sprinkler in the critical corner, then divide the distance of the critical line to evenly space the remaining sprinklers. If square spacing is used, there should be a sprinkler in each corner with evenly spaced sprinklers in between. If the layout is triangular, the spacing may cause an oddly placed sprinkler at the end.
7. Lay out the next row of sprinklers along a second critical line, such as the edge of a building. Fill in the interior area with evenly spaced rows of sprinklers. Adjust the spacing of the sprinklers and rows to fit the site.



NOTES

Review

1. Which sprinkler layout style is best suited to protecting borders?

2. What is the multiplier used to determine the row distance for triangular spacing? _____

3. Is knowing static pressure of the site necessary before laying out sprinklers? _____

4. Is the critical line of sprinklers usually along an edge or in the middle of a site? _____

5. Use Toro sprinklers to lay out the site in Figure 3.5 on the next page.



Scale 1" = 10'

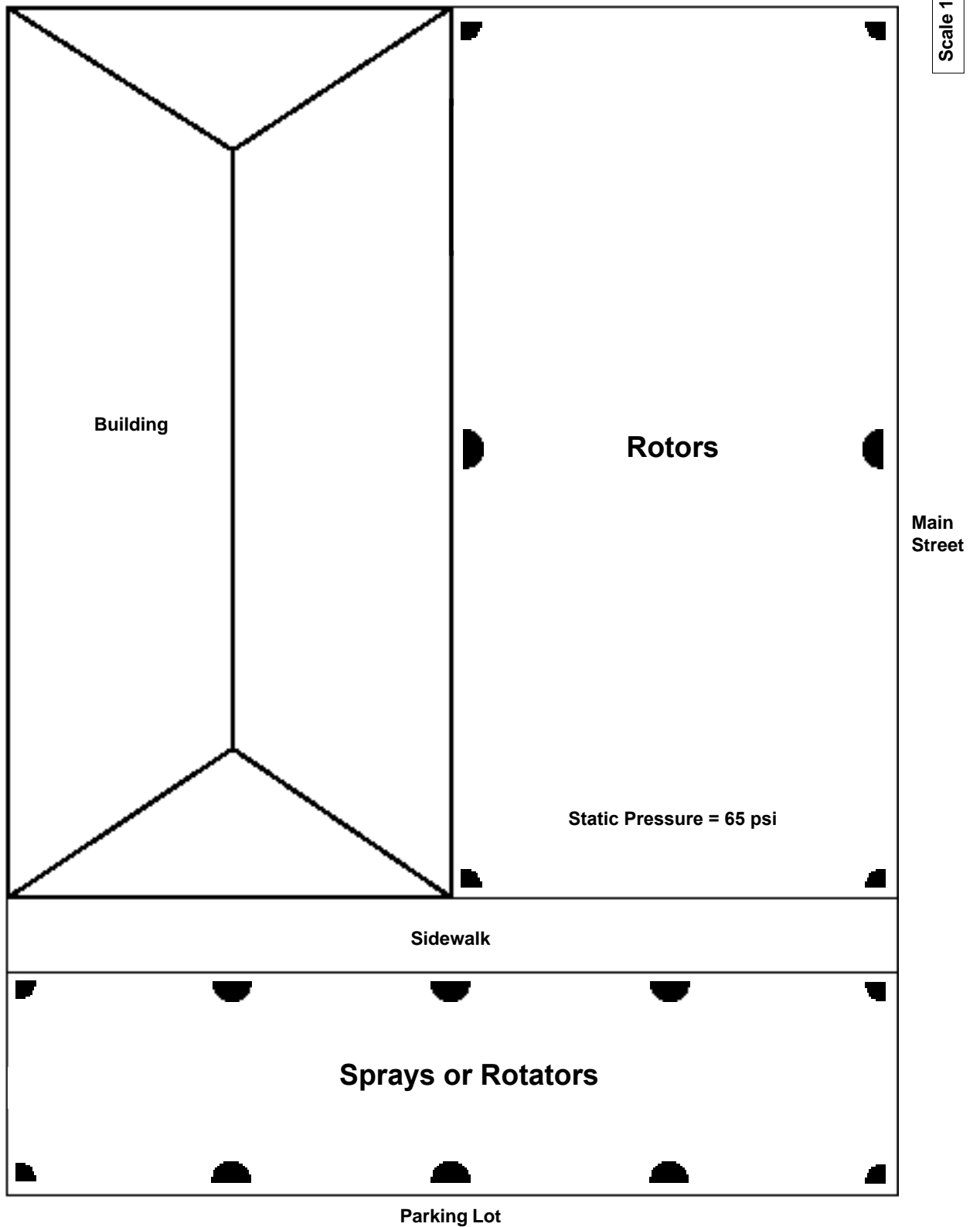

FIGURE 3.5

■ Zoning A System

The main purpose of grouping sprinklers together is to regulate the demand from the water source. This section covers the reasons for zoning an irrigation system and proper procedures. By zoning an irrigation system properly, different requirements within the site are irrigated independently. When zoning an irrigation system, the designer groups sprinklers together to run at the same time.

In the **Available Water** section in this workbook, we covered how to calculate the most efficient amount of water through a water meter and service line. Once this amount is determined, there should never be a demand from any zone on the system greater than the supply capacity.



If the demand in a zone is greater than the calculated available water, friction losses will increase throughout the system. The result is sprinklers that perform at less-than-optimum pressure, reduced radius and possible dry areas.

All of the sprinklers in a zone are connected with *lateral line pipe*.

The remote control valve is installed upstream from the sprinklers and connects to the main line pipe.

Although flow is very important in determining the number of zones in a system, it is not the only reason to group sprinklers together. Some of the other considerations for zoning include:

1. Grouping similar sprinklers with the same precipitation rate.
2. Separating varying plant material into different zones.
3. Irrigating sloped areas separately from level areas.
4. Zoning shaded areas separately from sunny areas.
5. Creating different zones for varying soil conditions.

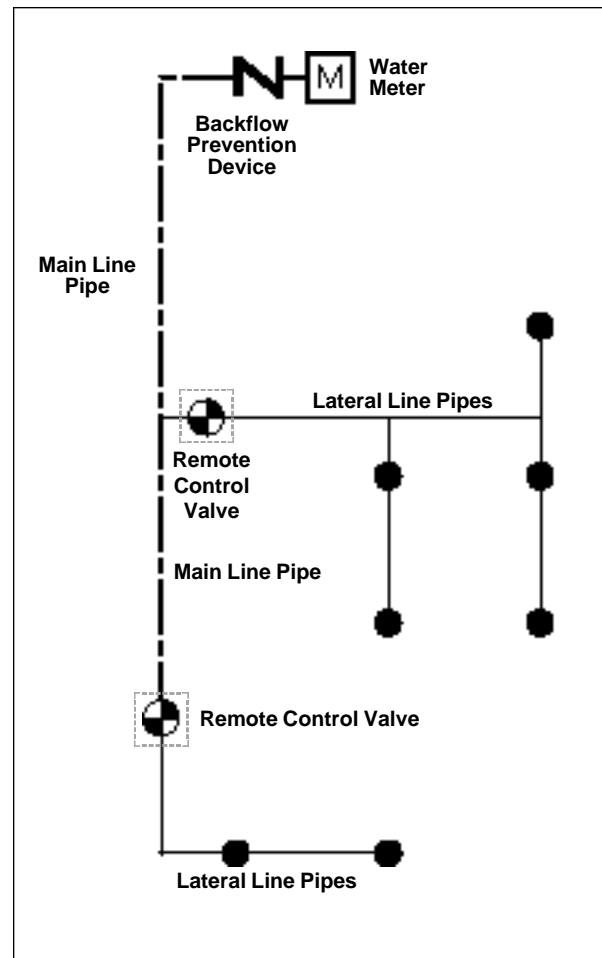

FIGURE 4.1

NOTES

Pipe Routing

Once it has been decided which groups of sprinklers will run together, the next step is to route the pipe. Routing connects the heads within a zone on the lateral line pipe and the valves to the water source on the main line pipe.

The lateral lines should be placed between the sprinklers and the valve location. It is usually best to run the lateral lines along the rows of sprinklers. This is especially true if the spacing is triangular in layout. The best pattern of piping looks like an “H” when designed properly. On slopes, the lateral pipe should run horizontally along the contours of the slope, not up and down. This minimizes pressure variations due to elevation changes within the zone.

Locating Valves

The remote control valves can be placed independently within the site (*remote location*) or grouped together with other valves (*manifolding*).

Remote location of valves produces minimal runs of lateral line pipes. This reduces friction loss and also allows the placement of valves in the optimum hydraulic locations within the system. The disadvantages of remote location include difficulty in locating valves on the

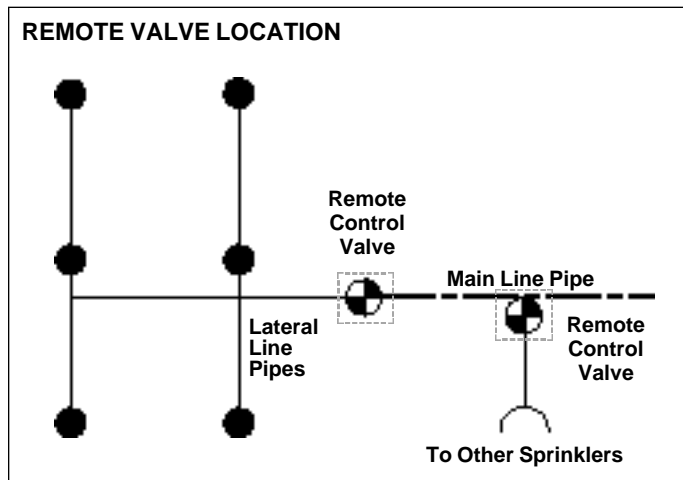

FIGURE 4.2

site after construction as well as an increased chance of damage to a valve or valve box from maintenance equipment.

Manifolding valves requires less wire from the valves to the controller location, and the valves are easily located for troubleshooting. Usually, the manifolded valves are located outside the landscaped or maintained area. Therefore, there is a reduced chance that damage may be caused by maintenance equipment. The main disadvantage of manifolding is that more pipe is needed to run from the valves to the sprinkler locations. Additionally, servicing the manifolded valves becomes difficult if valves are installed too close together.



NOTES

After the system is zoned, piped and begins to operate, the valves will typically operate in a sequential manner. Therefore, when one valve is open and operating, the remaining valves are closed.

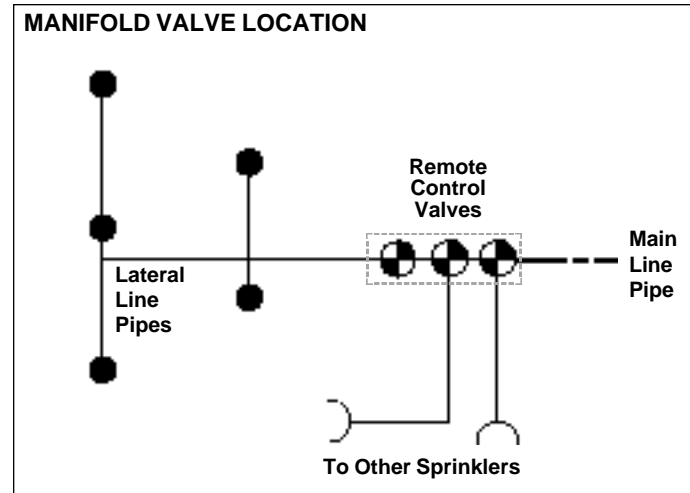

FIGURE 4.3

Review

1. If 25 sprinklers discharge 4 GPM each and the available water is 20 GPM, how many remote control valves should there be? _____
2. If a water supply is calculated to provide 20 GPM, should there be one zone designed to 25 GPM and another designed to 15 GPM within this system? _____
3. If there is similar plant material in an area with both heavy shade and sun, should all of the plants be on the same zone? _____
4. On a slope, should the lateral line pipes run vertically or horizontally to the slope? _____
5. Using Figure 4.4 on the next page, zone the system according to available water.



NOTES

- Zone 1 _____ GPM
- Zone 2 _____ GPM
- Zone 3 _____ GPM
- Zone 4 _____ GPM
- Zone 5 _____ GPM
- Zone 6 _____ GPM

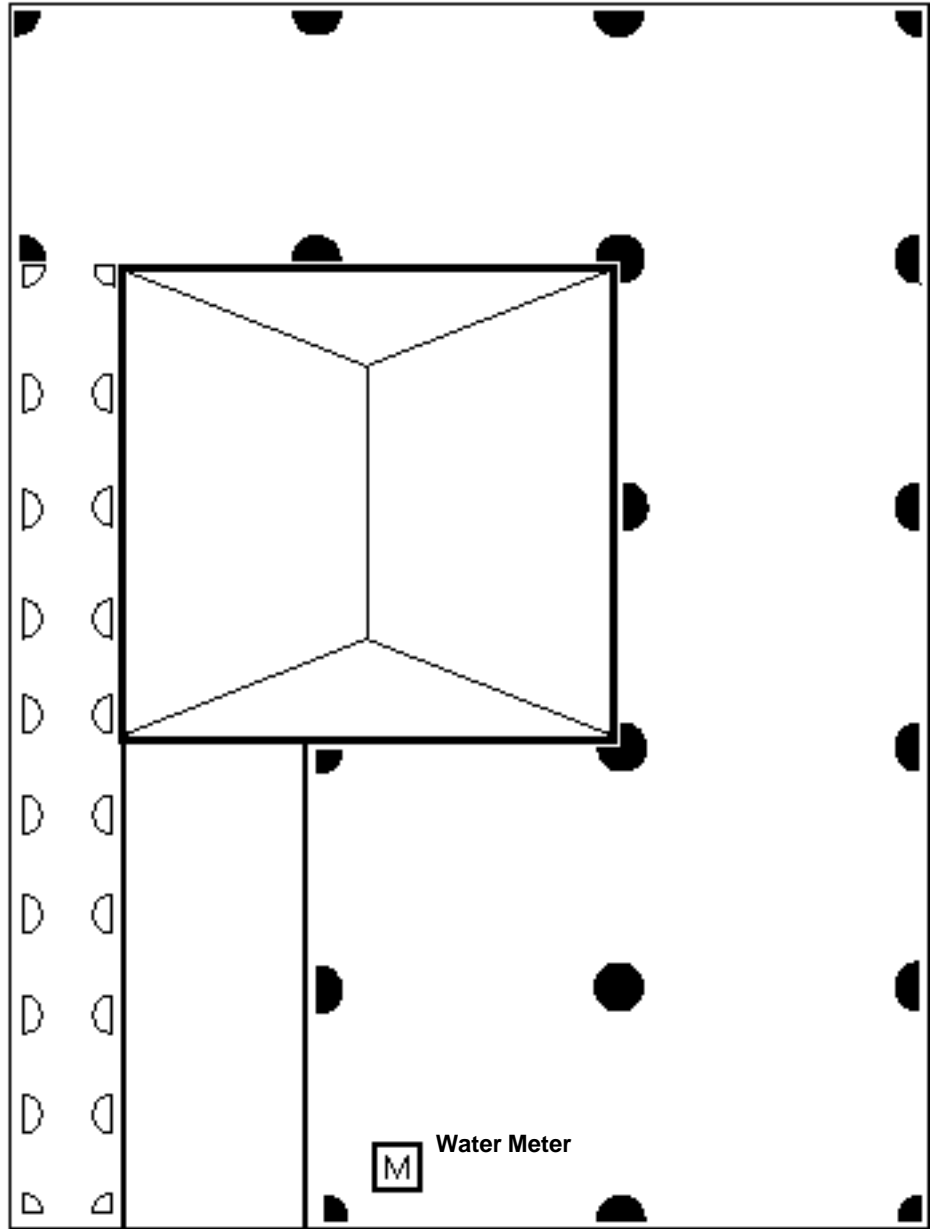

□ Spray-12-Q

● Rotor - 1.5

◐ Spray-12-H

◑ Rotor - 3.0

◒ Rotor - 4.5

● Rotor - 6.0

Available Water = _____

Design Pressure = _____

FIGURE 4.4



■ Pipe Sizing

The purpose of sizing pipe correctly is to ensure that the pipe delivering water to the sprinkler carries the required flow without excessive friction loss. In this section, the steps for properly sizing irrigation lateral and main line pipes are outlined. When pipe is sized properly, the irrigation system flows water at safe velocities with minimal friction losses.

There are several methods to determine the proper pipe size. One of the most common is the **velocity method**. Using the velocity method, the designer limits the speed in each segment of pipe supplying water to the sprinklers. The most agreed upon speed limit of water flow in pipe is 5 FPS. By limiting the speed to under 5 FPS, friction losses are also kept to a minimum.

The process of sizing pipe using the velocity method is as follows:

1. Begin at the sprinkler farthest from the remote control valve. Check the gallonage of the sprinkler at the estimated design operating pressure. This information comes from the *Toro Specification Catalog* nozzle data.
2. Choose the type of pipe needed for the system, for example, SDR 21 CLASS 200 PVC. Refer to the Velocity of Flow Chart in the *Toro Specification Catalog*.
3. Read down the far left column under FLOW GPM. Follow until the GPM of the sprinkler used in the design of the system, at its operating pressure, is located. To the right of this GPM, locate the smallest pipe size which flows the water under 5 feet per second.

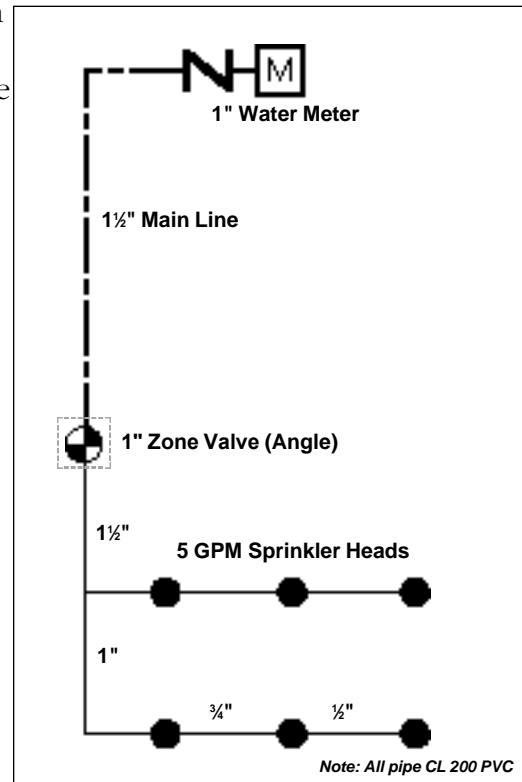

FIGURE 5.1

4. Continue adding the GPM from upstream sprinklers to each segment of pipe. Follow Step 3 for all segments. The pipes will increase in size closer to the remote control valves.
5. Valves are sized using the total GPM flow demand from all downstream sprinklers. Refer to the *Toro Specification Catalog* for valve sizing. Once the valve type is selected, it is sized by referring to the pressure loss charts in the *Toro Specification Catalog*. As velocity of water is limited in the pipes, there is a limit of allowable friction loss in the valve.

NOTES



The total flow of the downstream sprinklers should not create more than 5 PSI loss through the valve selected. If it is more than 5 PSI, a larger valve is required.

- To size the main line, follow the same procedures used on the lateral pipe using the maximum total flow from the largest remote control valve.

Review

- What is the allowable feet per second (FPS) velocity used to size pipe?

- What determines the amount of flow demand in the irrigation system pipes?

- What is the maximum allowable friction loss in any remote control valve and where is that information found?

- Size the lateral line pipes, main line pipe and remote control valves in Figure 5.2 below.

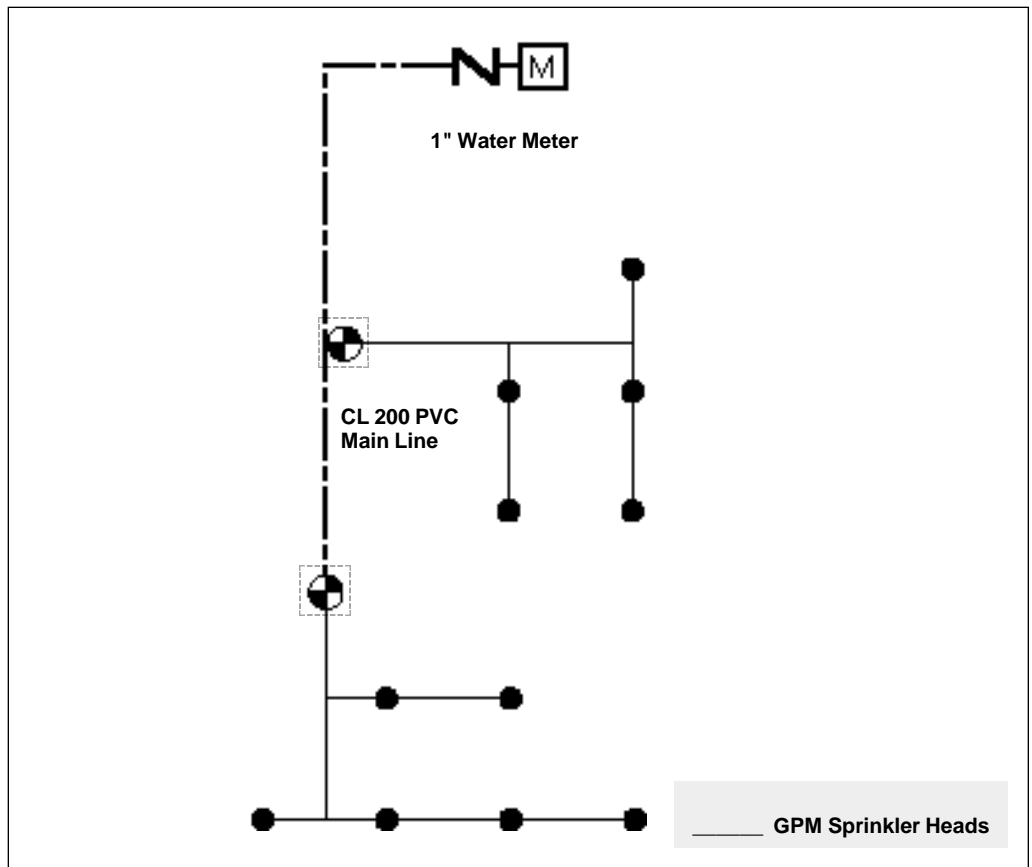

FIGURE 5.2

Basic Irrigation Design

■ System Operation Check

The purpose of performing a system operation check is to guarantee that the system operates at the proper design operating pressure selected previously. In order for the system to operate correctly the most critical sprinkler should have adequate design operating pressure.

A system operation check will alert the designer to any potential problems in the system, allowing for corrections to the design. This section includes the steps required to calculate friction losses in all components flowing water within the system.



The most critical sprinkler head on the system is usually located at the point farthest from the water source. It may also be the farthest sprinkler on the largest flow demand zone.

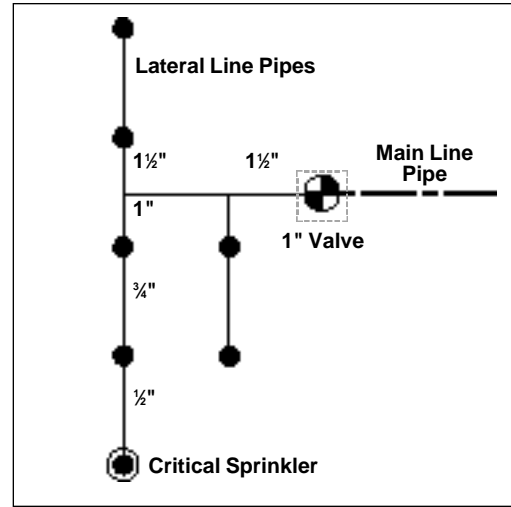

FIGURE 6.1

Friction losses occur through the following components of the irrigation system:

- service line
- water meter
- backflow prevention device
- main line pipe
- remote control valve
- lateral line pipes
- fittings

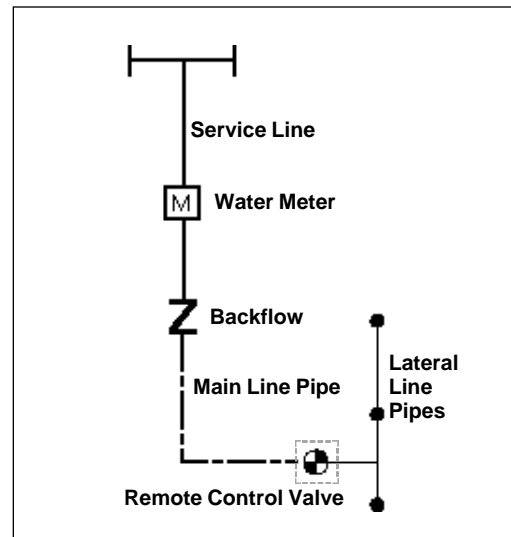

FIGURE 6.2

As outlined in the Hydraulics Section, an estimated amount of total friction loss should be used to decide sprinkler design operating pressure. For example, if 25 PSI is deducted from a static pressure of 65 PSI, then 40 PSI remains for design operating pressure.

Friction losses in the system should not be so great that they cause the design operating pressure to fall below 40 PSI.

NOTES

After all friction losses are calculated, the total amount is subtracted from the static water pressure. If the remaining pressure is **less than** the design operating pressure, the system design must be altered. If the remaining pressure is **greater than** the design operating pressure by approximately 10%, the hydraulic design is adequate.

Begin calculating the friction losses at the critical head and work back to the water source. Follow the direct path from the critical head to the water source.



Friction loss must be calculated on all components that carry water directly to the critical sprinkler. Flows increase through each piece of lateral line pipe as the losses are calculated toward the water source.

To calculate the friction loss in the lateral lines, refer to Figure 6.3. Section A is the closest pipe to the critical head, delivering 5 GPM through 50 feet of ½" PVC.

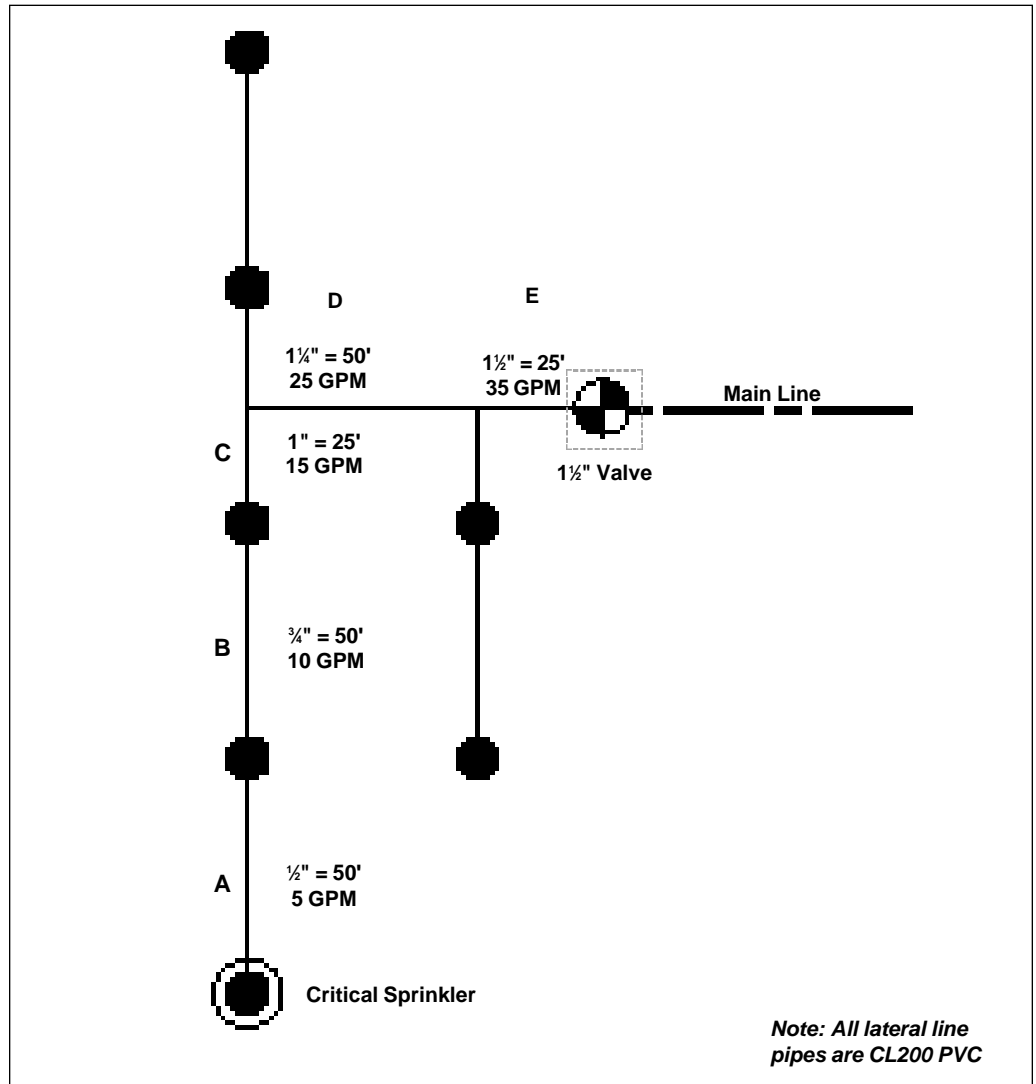

FIGURE 6.3



NOTES

Friction losses for CLASS 200 PVC are found in the *Toro Specification Catalog*. The FLOW GPM column is located at the left side of the page and the PIPE SIZE is across the top. Find 5 GPM in the FLOW GPM column. Directly to the right, the friction loss is indicated for the ½" pipe. It shows a loss of 4.76 PSI per 100 feet, which is converted to the actual length of 50 feet by multiplying 4.76 by .50. The loss per 50 feet = 2.38 PSI.

Pressure Loss From Friction per 100' of Pipe (lbs./sq. in.)									
SDR 21 / Class 200 PVC 1120, PVC 1220, PVC 2120 C = 140									
Flow GPM	½"	¾"	1"	1¼"	1½"	2"	2½"	3"	4"
1	0.25	0.07							
2	0.90	0.24							
3	1.90	0.52							
4	3.24	0.88	0.26						
5	4.89	1.33	0.39						
6	6.86	1.86	0.55						
7	9.12	2.47	0.73						
8	11.68	3.17	0.94	0.30					
9	14.53	3.94	1.17	0.37					
10	17.66	4.79	1.42	0.45	0.23				

FIGURE 6.4

Section B is calculated the same way as Section A, but the flow increases in the pipe to 10 GPM because the pipe is delivering water to two sprinklers, each demanding 5 GPM. As the calculations are done for each pipe, the flow continues to increase due to sprinkler demand downstream. The process of calculating the friction loss is the same.

Then the pressure loss through the lateral fittings is calculated using 10% of the total lateral pipe pressure loss. The same is done for the pressure loss in the mainline fittings.

Examine the following calculations for the example:

- Section A: $4.89 \text{ psi}/100\text{ft} \times 50\text{ft} = 2.445 = 2.45 \text{ psi loss}$
- Section B: $4.79 \text{ psi} /100\text{ft} \times 50\text{ft} = 2.395 = 2.40 \text{ psi loss}$
- Section C: $3.38 \text{ psi}/100 \text{ ft} \times 25\text{ft} = 0.845 = 0.85 \text{ psi loss}$
- Section D: $2.62 \text{ psi}/100 \text{ ft} \times 50\text{ft} = 1.31 \text{ psi loss}$
- Section E: $2.45 \text{ psi}/100 \text{ ft} \times 25\text{ft} = 0.6125 = 0.62 \text{ psi loss}$
- Total Lateral Pipe PSI Loss = 7.63 psi loss
- PSI Loss in Lateral Fittings $7.63 \times 0.10 = 0.77 \text{ psi loss}$
- Total Lateral Line PSI Loss = 8.40 psi loss**

NOTES

Review

1. Is a system friction loss check necessary to determine if the irrigation system will operate properly? _____

2. Which sprinkler on the irrigation system should be checked for correct operating pressure? _____

3. Where is the zone containing the critical head typically located in the irrigation system? _____

4. Is it necessary to check the friction loss through the backflow prevention device when doing a system friction loss check? _____

5. Determine the critical head in Figure 6.5 on the next page. Then, calculate the working pressure at the critical head.



NOTES

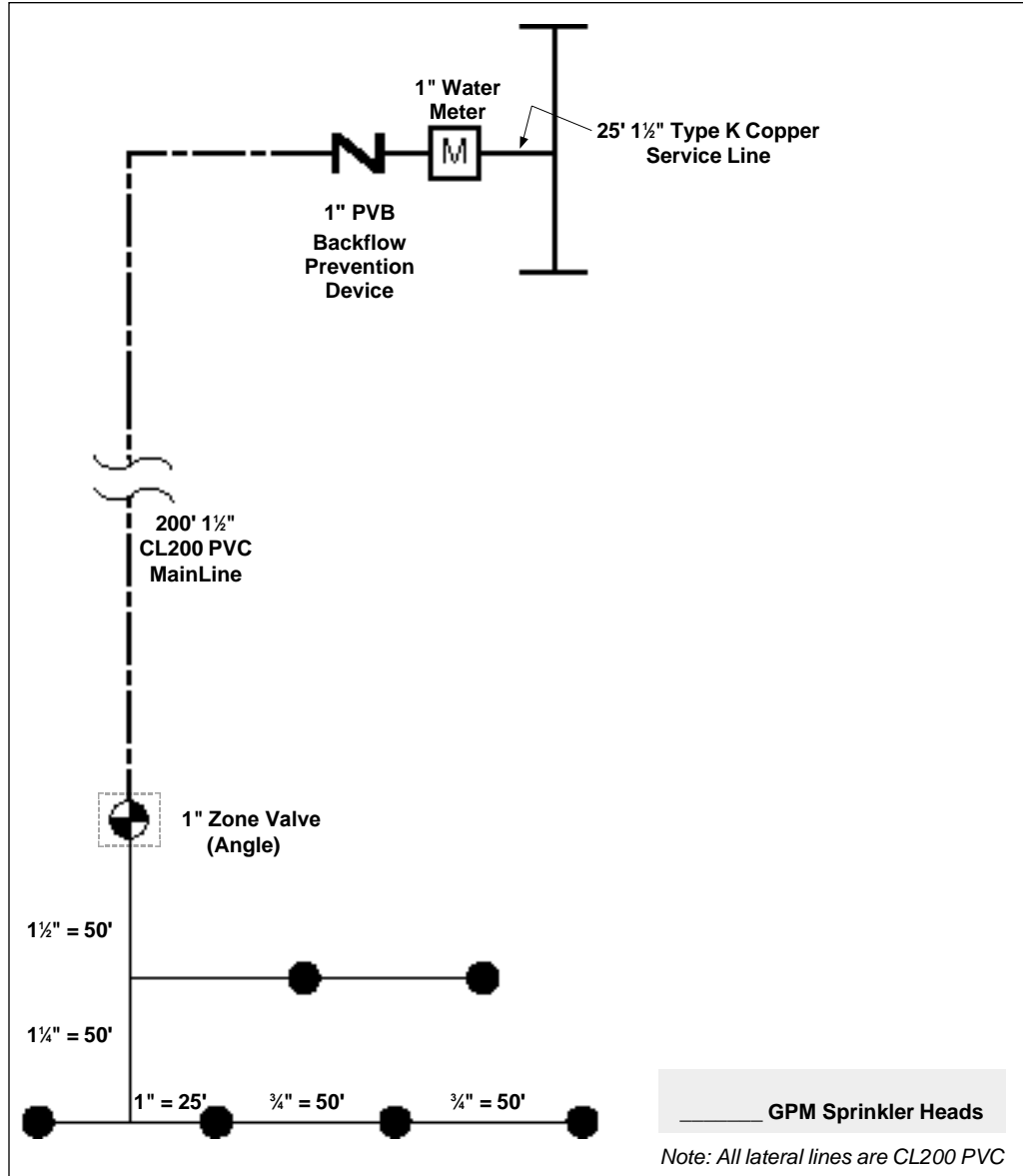

FIGURE 6.5

FRICTION LOSS CALCULATION	
Lateral Line _____ PSI	Static Pressure _____ PSI
Main Line _____ PSI	Total PSI Loss _____ PSI
Fittings (10%) _____ PSI	
Zone Valve _____ PSI	Working Pressure _____ PSI
Backflow _____ PSI	Design Operating Pressure _____ PSI
Water Meter _____ PSI	
Service Line _____ PSI	
Total PSI Loss _____ PSI	



DESIGN CHECKLIST

- Measure the site and record specific irrigation requirements.
- Determine the size and location of the water meter.
- Determine the type of material, size and length of the service line from the city water main to the proposed location of the backflow prevention device.
- Measure and record the static water pressure.
- Estimate the amount of friction loss in the entire system.
- Determine the design operating pressure from the estimated friction losses.
- Calculate the available water on the site.
- Divide the site into separate, smaller geometric shapes.
- Choose the type of spacing needed, square/rectangular or triangular.
- Find the critical line and critical corner on the site and lay out the first row of sprinklers.
- Continue placing sprinklers until the site is covered adequately.
- Determine the number of zones from the available water and total number of sprinklers.
- Route the lateral line pipe and the control valves.
- Route the main line pipe.
- Size the lateral lines, remote control valves, main lines and backflow prevention device.
- Check for total friction losses from the P.O.C. to the most critical head on the system.
- Make any necessary adjustments to component sizes and design.

Basic Irrigation Design

■ Suggested Reading

1. Melby, Pete • 1995 • Simplified Irrigation Design, Second Edition • Van Nostrand Reinhold • New York, NY.
2. Rochester, Eugene • 1995 • Landscape Irrigation Design • American Society of Agricultural Engineers • St. Joseph, MI.
3. Sarsfield, A. C. • 1966 • The ABCs of Lawn Sprinkler Systems • Irrigation Technical Services • Lafayette, CA.
4. Smith, Stephen W. • 1996 • Landscape Irrigation: Design and Management • John Wiley & Sons • New York, NY.
5. Weinberg, Scott S. • 1988 • Handbook of Landscape Architectural Construction - Irrigation • Landscape Architecture Foundation • Washington, DC.



The Toro Company • Irrigation Division • An ISO 9001-Certified Facility
• PO Box 489 • Riverside, CA • 92502 • Phone (800) 654-1882 • www.toro.com